

Branchement du module Wig Wag Dimmer™

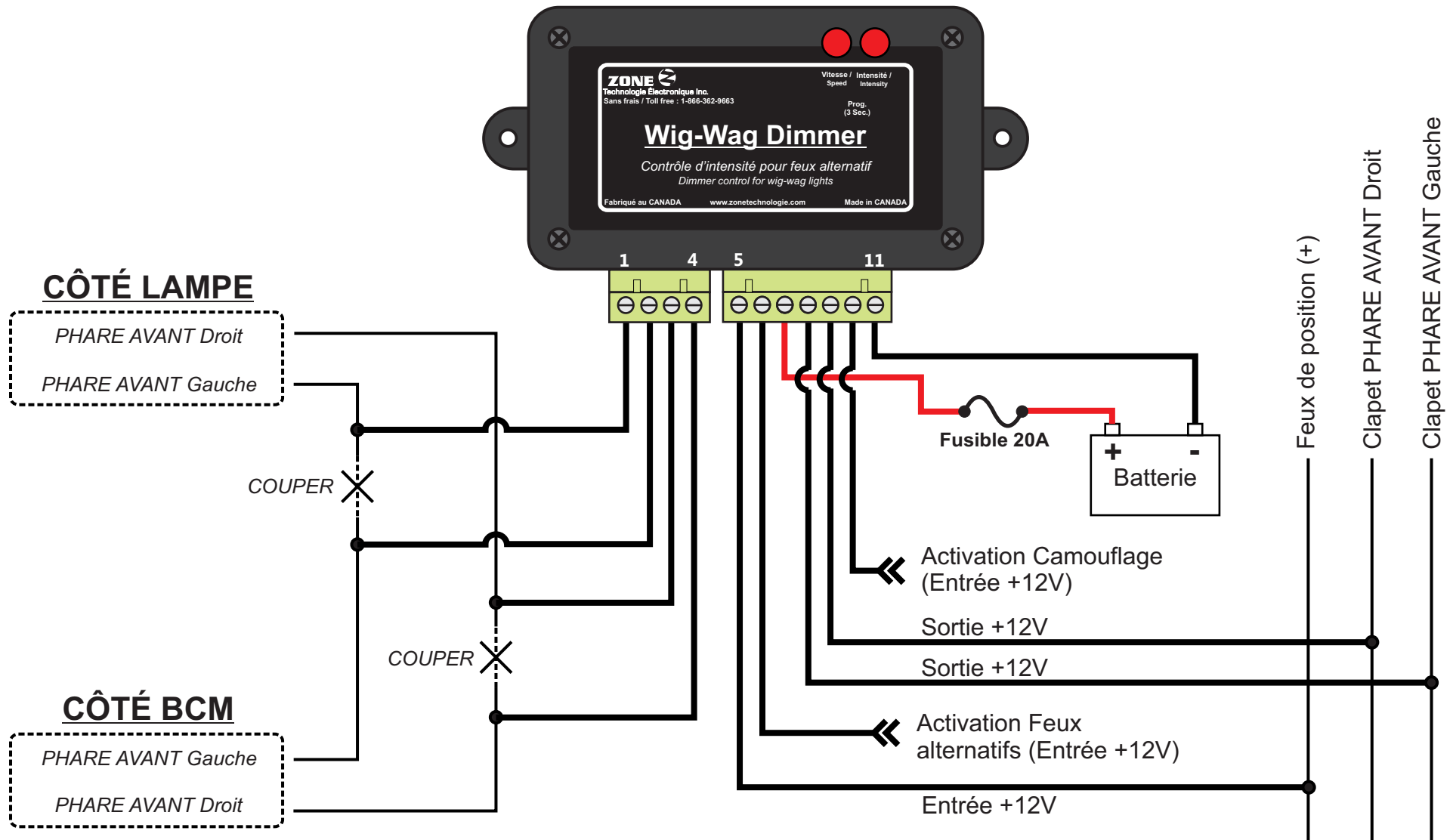

Technologie Électronique Inc. | L'innovation en mouvement

Sans frais / Toll free : 1-866-362-9663

www.zonetechnologie.com